

# Salt Water Electrolysis

## Atecpool Commercial Salt Chlorinator



### ATEC500CM

### USER MANUAL



#### IMPORTANT:



- The unit must imperatively be connected to a protective earth conductor.
- The unit must imperatively be protected by a 30 mA residual current circuit breaker .
- Only qualified and authorized personnel should open the electrical cabinet. Risk of electrical shock or fire hazard. 230VAC.
- The unit must imperatively be installed after the filter and must be the last element the water passes through before returning to the pool.

## **CONTENTS**

1. Security warnings.....	3
2. Unit description .....	4
3. Installation.....	5
4. Cell connections.....	5
5. Electrical connections.....	6
6. Operation.....	6
6.1 Screen indications	
6.2 ON/OFF switching	
6.3 ON state: production	
7. Screen messages.....	8
8. Menus.....	9
9. Regular maintenance.....	10
10. Warnings.....	11

## 1. SECURITY WARNINGS



- Before attempting the installation or any manipulation on the unit make sure the it is disconnected from the power mains.
- The unit should be connected to a proper **protective earth conductor**.
- The unit should be protected by an external **30 mA residual circuit breaker**.
- Do not operate the chlorinator if the pump is not running or if the flow through the cells is too low. The gas generated in the electrolytic proceeds could break the cell and eventually explode.
- Do not install the chlorinator before the filter or any other element. The chlorinator must be the last element the water passes through before returning to the pool. Otherwise the gas generated in the cell could build up in the circuit and cause an explosion.
- Install the unit in a fresh and well ventilated area and protected from flooding and liquid splashes
- Only qualified technical personnel should manipulate the unit. The manufacturer declines any responsibility derived from the installation, the start up and from any manipulation or added component not factory installed.

## 2 . UNIT DESCRIPTION

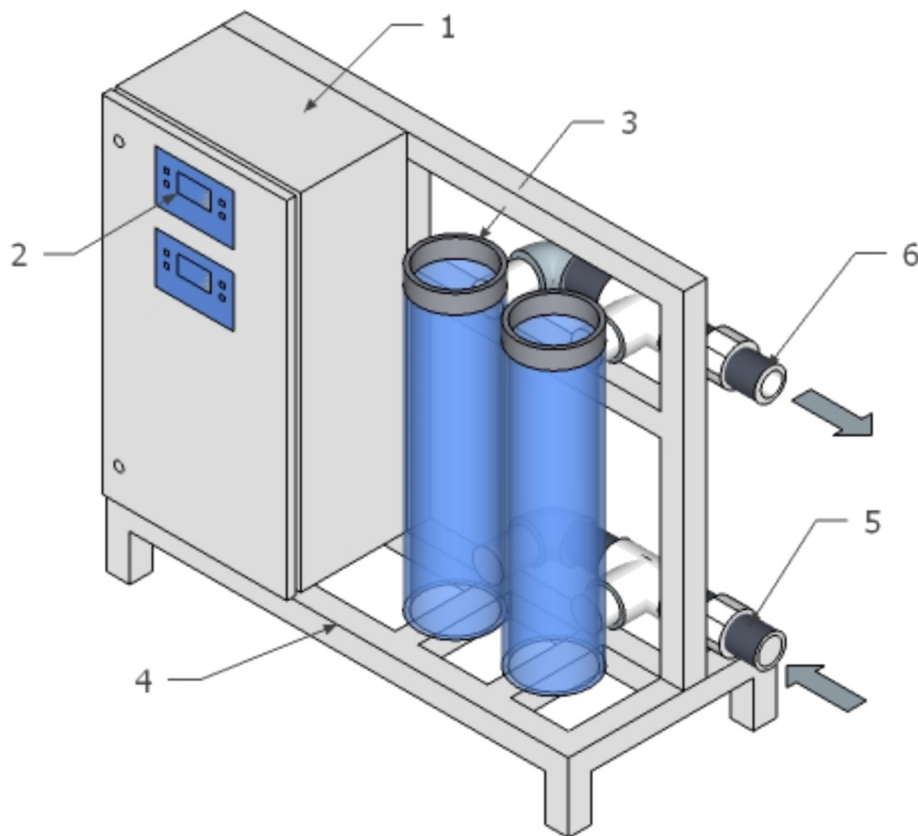

The ATEC500CM is an high performance electrolytic chlorine generator. The unit produces pure chlorine, without any additives, directly from water with a salt concentration above 4.0 gr/l. The chlorinator is installed in-line in the pool filtration circuit. Part of the return water flow is forced through its cells by means of a by-pass placed at the end of the circuit, once the water has passed through the filter and through any other element and just before the return to the pool. When passing through the cells, the water acquires a high and very effective chlorine concentration capable of destroying most contaminants.

The ATEC500CM main elements are:

**1. Power and control cabinet.** It houses the control and power units. The power supply and external control cables enter the cabinet through its back side.

**2. Control keyboard and display.** Each assembly keyboard-display allows for independent control of each of the electrolytic cell tubes.

**3. Electrolytic cell tubes.** They hold the electrolytic cells. Each tube is powered by four cell cables with four cell connectors.: Two black connectors in the centre and two blue connectors on the sides.

**4. Stainless steel frame.** It supports the cabinet, the cell tubes, the plumbing and the flow switch.

**5. Water inlet.** Fitted with a 75 mm pipe threaded union.

**6. Water outlet.** Fitted with a 75 mm pipe threaded union.

### 3. INSTALLATION OF THE UNIT

Install the unit in a fresh and well ventilated place. The top of the cabinet and the heat sink area should always be kept clear of any objects. The chlorinator must be fed with filtered water. Install a by-pass at the end of the return water flow: once the water has passed through the filter and through any other element and just before the return to the pool. Send the flow into the cells by partially closing the main pipe valve until you obtain a rapid and smooth flow through the cells.



**Do not install the chlorinator before the filter or any other element. The chlorinator must be the last element the water passes through before returning to the pool. Otherwise the gas generated in the cell could build up in the circuit and cause an explosion.**



**Water must imperatively enter the cells by their lower inlet (5) and leave the cells by the upper outlet (6). The inlet and outlet tubes are marked with arrows indicating the water flow direction.**

When the cells are being filled with water, the air trapped in the tubes can prevent the water to flow. You can temporarily loose the flow switch in order to evacuate the air inside. Once the cell tubes are completely filled, don't forget to retighten the flow switch. Verify that the arrow marking on the flow switch corresponds to the water flow direction after retightening.

Water must flow at sufficient speed trough the cells. If the flow is too low, scale could build on the electrodes. If the installation is not provided with a dedicated pump for the chlorinator, adjust the flow rate by acting on the by-pass centre valve.



**When water is being injected into the cells, make sure that there aren't any CLOSED VALVES downstream because the pressure generated will break the cell tubes. Similarly, NEVER CLOSE any valves downstream when the pump is running.**



**Verify that the locking cell rings are properly installed before starting the pump. Press the rings outwards along their entire length to make sure they are entirely inserted in the slots .**

### 4. CELL CONNECTIONS

The cell cables are connected in the factory and ready to operate. Each cable has a fixed position on the cell pins. When you will have to remove the cables, make sure to reconnect them in the same position. The colour of the pins on the cell must match the colour of the cables.

Check periodically that the pins are tighten and if it is not the case tighten them preferably by hand. An excessive tightening is not necessary and will damage the cell.

Avoid any water build up on the cell cap. Always keep the cell cap, pins and connectors perfectly dry and clean.

## 5. ELECTRICAL CONNECTIONS

### Power supply cable

The chlorinator must be powered with 230 VAC. Connect the three-wire power supply cable (marked “230 VAC power supply”) to a permanent 230 VAC mains power supply with protective earth. The power on this cable must be kept constant as long as the chlorinator is in use. **DO NOT INTERRUPT** the power on this cable with the pump working cycles or by means of any other control device. In order to control the chlorinator production cycles use the External Control Cable. Disconnect the power supply only when you are not going to use the chlorinator or in case of fault.



**The chlorinator must imperatively be connected to a proper protective earth through its power supply cable and protected by a 30 mA residual circuit breaker.**

### External Control Cable

The two-wire cable marked “**EXTERNAL CONTROL 230VAC**” is used to start and stop the chlorine production synchronically with the pump working cycles or by means of a control device. When the voltage applied between the two wires is 230VAC the chlorinator will produce chlorine. When the voltage between the wires is 0 VAC the chlorinator will halt the chlorine production and enter a pause mode. Therefore, the voltage applied to the control cable must be driven by the same means, signal or device that powers or controls the pump.



**Make sure that the voltage applied to the External Control Cable is 230VAC ONLY when the pump is running and the water flows freely through the cells and to the pool.**

## 6. OPERATION

The ATEC500CM unit controls its two electrolytic cells independently thanks to its two keyboard-display assemblies. In a electrolytic cell chlorine generation is proportional to the electrical current flowing through it. The ATEC500CM will try to maintain a constant electrical current in the cells according to the chlorine production rate (0—100%) set by the user. The current and voltage values in each cell are constantly displayed in the main screen. In normal conditions, and at 100% production rate, the current values (I) must be between 18 and 20 A which indicate a total chlorine production rate of 500 g/h.

### 6.1 Main Screen readings

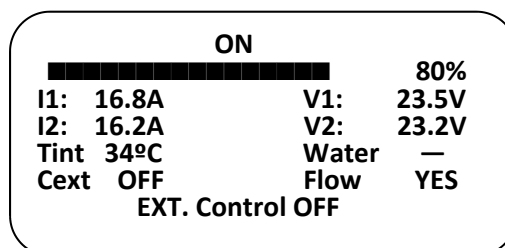

**D** escription:

<b>ON</b>	→	Chlorinator state
████████████████████	→	Chlorine production setting
<b>I1: 16.8A</b>	→	Cell 1 working values
<b>V1: 23.5V</b>		

<b>I2: 16.2A</b>	<b>V12 23.2V</b>	→	Cell 2 working values	
<b>Tint 34°C</b>	<b>Water —</b>	→	Temperatures	Water detector state
<b>Cext OFF</b>	<b>Flow YES</b>	→	Ext. control state	Flow Switch state

**ON/OFF:** indicates the operation state. To alternatively change the state press the **MENU (ON/OFF)** key for at least two seconds.

**Production setting:** Indicates the actual chlorine production rate. It can be adjusted by pressing the **↑** or **↓** keys.

**I1, V1, I2, V2.:** Indicate the cell working values and provide a valuable information for checking and diagnose. At 100% production rate and in normal conditions I1 and I2 should be between 18 and 20 A

**Tint:** Cabinet interior temperature.

**Water:** Water sensor state (— when not implemented).

**C. Ext** External control state (signal read by the External Control Cable).

**Flow:** indicates the flow switch state.

## 6.2 Switching the unit ON and OFF

To alternatively switch the unit ON and OFF, make sure you are in the main Screen and press the **MENU (ON/OFF)** key for about two seconds. If the display was not in the Main Screen, you can always come back to it by pressing one or several times the **MENU** key. The unit state (ON or OFF) is indicated in the upper line of the display.

When you connect the mains power supply for the first time, the displays will light and will remain in **OFF** state. Depending on how the unit has been programmed, whenever the mains is disconnected, the unit will remain in **OFF** state or will remember its previous state (ON or OFF) once the mains power has been restored.

**To control the chlorine production according to the pump running cycles or any other signal use the External Control Cable as explained in section 5. DO NOT disconnect and reconnect the mains power supply cable.**

When the unit is in **OFF** state the chlorine production is not allowed but you will still have access to the production settings, menus and to all working parameters.

## 6.3 ON state : Chlorine production

By pressing the **MENU (ON/OFF)** key for two seconds the display will indicate **ON** on its upper line and the chlorine production (provided Flow is ON, Cext ON, etc) will start. The **I1, I2, V1, V2** values will increase progressively until they reach their working point. You can adjust the chlorine production rate at any moment by pressing the **↑** or **↓** keys. There is a minimum production adjustable rate (normally 30%) to prevent the cell to work out of its optimal conditions range.

In **ON** state, the chlorine production is started or halted according to the External Control Cable signal. This signal is always displayed on the screen next to the **Cext** label:

- When the External Control Cable signal is ON (230 VAC between its wires), the **Cext** reading turns **ON** and the chlorine production is started.
- When the External Control Cable signal is OFF (0 VAC between its wires), the **Cext** reading turns **OFF** and the chlorine production is halted until the signal turns on again. This pausing state is also indicated on the screen bottom line with the message **CONTROL EXT. OFF**. Be aware that, even if the production is halted, the unit is still in **ON** state.

## 7. DISPLAY MESSAGES

The lower line on the screen is used to indicate certain states or faults.:

### **CONTROL EXT. OFF**

This message is displayed when the unit is in ON state but the control signal is in OFF state (external control cable wires at 0 VAC). The production is halted until the signal will turn back ON.

### **NO FLOW**

The flow switch has detected NO FLOW. The system stops the production and turns the unit to OFF state. If the user press OK to confirm the message, the unit will stop displaying the message and will then remain in OFF state indefinitely until the user turns the unit ON again (**MENU (ON/OFF) + 2 seconds**). If water flow is detected again before the user has pressed OK, the unit will come back to ON state and the chlorine production will resume.

### **CELL NOT DETECTED**

The system does not detect the cell and turns the unit OFF. Check that cell is properly connected or that the water contains salt. Press OK to confirm the message. The system will stop displaying the message and the unit will remain on OFF state. Once the problem has been solved, the user can turn the unit ON again.

### **LOW SALT**

The estimated salt concentration is lower than the optimum working range. The unit will remain in ON state and the chlorine production will continue normally. This message can also be displayed if the water is too cold, the electrodes are worn-out or calcium has built up in the cell.

### **SALT TOO LOW**

The estimated salt concentration too low and out of the working range. The system will stop the production to avoid damage to the cell. This message can also appear if the cell is not properly connected. Press OK to confirm the message. The system will stop displaying the message and the unit will remain on OFF state. Once the problem has been solved, the user can turn the unit ON again.

### **PAUSE 04:54**

When the system is carrying out a polarity inversion, the unit enters a pause mode and the remaining time is displayed on the screen.



## 8. MENUS

To enter the menus, press the MENU key and move up or down among the different sub-menus using the ↓ and ↑ keys. To enter a particular sub-menu press OK. Once in a sub-menu use ↓ or ↑ to change a parameter, MENU to go to the next parameter and OK to confirm and save changes. Then, use MENU one or several times to come back to the Main Screen.

### 8.1 Functions menu

#### 8.1.1 Language

Select the language and press **OK**.

#### 8.1.2. LCD Contrast

This menu is no longer implemented . In order to be able to adjust the contrast even when an incorrect setting does not allow to read the screen, a potentiometer marked with “**CONTRASTE**” has been mounted on the PCB, in the reverse side of the display. If you need to adjust the contrast, open the cabinet door and use a small screwdriver to turn it slowly until the contrast is OK.

#### 8.1.3. Readings

This is an only-read screen that provides a list of system measurements. These values are used for diagnose in technical support.

#### 8.1.4. 4-20 mA Control

Activate or deactivates the 4-20 mA external control.

#### 8.1.5. pH Adjustment —option

Follow the instructions joined when the pH option has been included.

### 8.2 Status menu

This is an only-read screen that provides a list of system measurements. These values are used for diagnose in technical support.

### 8.3. Programming menu

The access to this menu requires a password. **DO NOT enter this menu or try to change any of its parameters. Any parameter alteration will reconfigure the system and lead to a fail of the security systems.**

## 9. REGULAR MAINTENANCE

The ATEC500CM requires a minimal maintenance limited to the inspection and cleaning of the cell and its connections. Nevertheless, this minimal maintenance is fundamental for good operation and performance of the unit and to avoid future expensive failures.

### 9.1 Cells

Inspect the cells frequently. The electrodes blades should be clean and free from any build up or objects. The water must flow rapidly and without any obstacle through the tubular cells to avoid calcium build up. If you observe high turbulence over the water inlet areas or a low circulation speed, increase the water speed through the cells by sending more flow thorough the by-pass. (closing the central valve). If the water hardness is very high, even a high flow won't prevent the calcium from building up. If you observe high calcium build-up decrease the polarity period and make sure the water pH stays close to 7.0

The polymer seal under the cell cap and the protective sleeves of the electrode rods must both be intact. If any damage is observed, send the cell to the technical service for inspection and reconditioning.

The electrodes of the ATEC500CM cell have been build using the most advanced technique in the market and with a very high quality control. However, there are several situations that can reduce the performance and the life span of any electrode and you should avoid them:

- Operation with a low water level or flow in the cell
- Operation with scale build up on the electrodes
- Frequent acid cleansing
- Water pH too high or too low
- Acid injection before the cell

### 9.2 Cell pins

Inspect regularly the connection area of the cells and make sure it's completely dry and clean. Turn the unit OFF and remove the cell connectors. Verify that all the pins are tighten.



**Tighten the pins preferably by hand. If you use a wrench, do it very carefully because you could easily damage the sealing or the electrodes.**

## 10. WARNINGS



- **NEVER** power the unit without being connected to a protective earth conductor.
- **NEVER** operate the chlorinator without an external 30 mA residual circuit breaker protection.
- **NEVER** operate the chlorinator if the pump is not running or if the flow through the cells is too low. The gas generated in the electrolytic proceeds could break the cell and eventually explode.
- **NEVER** install the chlorinator before the filter or any other element. The chlorinator must be the last element the water passes through before returning to the pool. Otherwise the gas generated in the cell could build up in the circuit and cause an explosion.
- **DO NOT** access the Programme menu or change any parameter in it.
- **ALWAYS** keep the cell caps, cell terminals, and cell connectors completely dry. Salty water or moisture will create an electrolytic process and corrode the connectors rapidly..
- **ALWAYS** keep acid tanks away from the unit room.